



SIDDHARTH GROUP OF INSTITUTIONS :: PUTTUR
Siddharth Nagar, Narayanavanam Road – 517583

QUESTION BANK (DESCRIPTIVE)

Subject with Code : EC-II (19EE0202)

Course & Branch: B.Tech - EEE

Year & Sem: II-B.Tech & I-Sem

Regulation: R19

UNIT-I

THREE PHASE CIRCUITS

1. Derive the relationship between Phase and Line voltages, currents in star connected load. [L3][CO4][10M]
2. Derive the relationship between Phase and Line voltages, currents in delta connected load. [L3][CO4][10M]
3. A three phase balanced delta connected load of $(4+j8) \Omega$ is connected across a 400V, 3 ϕ balanced supply. Determine the phase currents and line currents. And also power drawn by the load. Assume RYB phase sequence. [L3][CO1][10M]
4. A balanced star connected load having an impedance $(15+j20) \Omega$ per phase is connected to a three phase 440 V, 50Hz supply. Find line currents and phase voltages. Assume RYB phase sequence and also calculate power drawn by the load. [L3][CO1][10M]
5. A balanced star connected load of $(4+j3) \Omega$ per phase is connected to a balanced 3 ϕ 400v supply. Find a) active power b) reactive power c) Apparent power. [L3][CO1][10M]
6. A balanced delta connected load of $(4+j3) \Omega$ per phase is connected to a balanced 3 ϕ 440v supply. Find a) active power b) reactive power c) Apparent power. [L3][CO1][10M]
7. Three impedances $Z_1=20L^{30}$, $Z_2=40L^{60}$, $Z_3=10L^{-90}$ are delta connected to a 400V, 3 ϕ System. Determine i) phase currents ii) line currents iii) total power consumed by the load. [L4][CO4][10M]
8. An unbalanced 4 wire star connected load has a balanced voltage of 400V. The load are $Z_1=(4+j8) \Omega$, $Z_2=(5+j4)\Omega$, $Z_3=(15+j20)\Omega$. Calculate line currents, current in neutral wire, total power. [L4][CO4][10M]
9. A 400V, 3 ϕ supply feeds an unbalanced 3 wire star connected load. The branch impedances of the load are $Z_R=(4+j8)\Omega$, $Z_Y=(3+j4)\Omega$, $Z_B=(5+j20)\Omega$. Find the line currents and voltages across phase impedance. Assume RYB phase sequence. [L4][CO4][10M]
10. a) Write the voltage and current relationship in star connected system? [L1][CO4][2M]
 b) Write the voltage and current relationship in star connected system? [L1][CO4][2M]
 c) What are the different methods are used to solve the unbalanced systems [L1][CO1][2M]
 d) Draw the star connected load. [L1][CO4][2M]
 e) Draw the delta connected load. [L1][CO4][2M]



SIDDHARTH GROUP OF INSTITUTIONS :: PUTTUR
Siddharth Nagar, Narayanavanam Road – 517583

QUESTION BANK (DESCRIPTIVE)

Subject with Code : EC-II (19EE0202)

Course & Branch: B.Tech - EEE

Year & Sem: II-B.Tech & I-Sem

Regulation: R19

UNIT-II
TRANSIENT ANALYSIS

1. Derive the transient response of an RL circuit with dc excitation. [L4][CO2][10M]
2. Derive the transient response of an RC circuit with dc excitation. [L4][CO2][10M]
3. Derive the transient response of an RLC circuit with dc excitation. [L4][CO2][10M]
4. Derive the transient response of an RL circuit with Ac excitation. [L4][CO2][10M]
5. Derive the transient response of an RLC circuit with AC excitation. [L4][CO2][10M]
6. Derive the transient response of an RC circuit with AC excitation. [L4][CO2][10M]
7. A series RL circuit with $R=30\Omega$ and $L=15H$ has a constant voltage $V=60V$ applied at $t=0$. Determine the current I , the voltage across the resistor and across the inductor. [L3][CO2][10M]
8. A series RC circuit consists of resistor of 10Ω and capacitor of $0.1F$ has a constant voltage of $20v$ is applied to the circuit at $t=0$. obtain the current equation. Determine the voltage across the resistor and the capacitor. [L3][CO2][10M]
9. In the circuit shown in fig. Determine the complete solution for the current when switch is closed at $t=0$, applied voltage is $V(t)=50\cos(10^2t+\pi/4)$, resistance $R=10\Omega$ and capacitance $c=1\mu F$. [L3][CO2][10M]

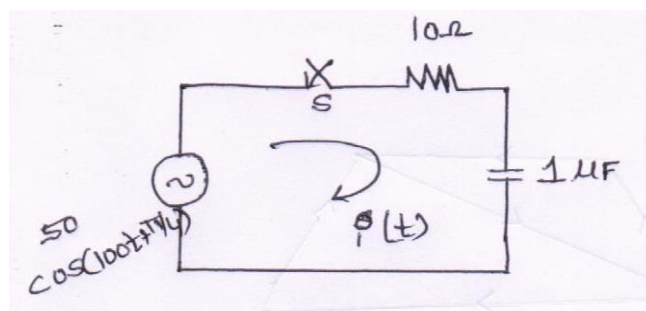

- 10.a) Define steady state. [L1][CO2][2M]
- b) Define transient state. [L1][CO2][2M]
- c) Find the Laplace transform of the function $f(t) = 4t^3 + t^2 - 6t + 7$? [L3][CO2][2M]
- d) Find $L\{\cos^2 t\}$? [L3][CO2][2M]
- e) What is the transient response of RL series circuit with dc excitation? [L1][CO2][2M]



SIDDHARTH GROUP OF INSTITUTIONS :: PUTTUR

Siddharth Nagar, Narayanavanam Road – 517583

QUESTION BANK (DESCRIPTIVE)

Subject with Code : EC-II (19EE0202)

Course & Branch: B.Tech - EEE

Year & Sem: II-B.Tech & I-Sem

Regulation: R19

UNIT -III

NETWORK TOPOLOGY

1. Find the cutset matrix for the followings?

a) [L3][CO3][5M] b)

[L3][CO3][5M]

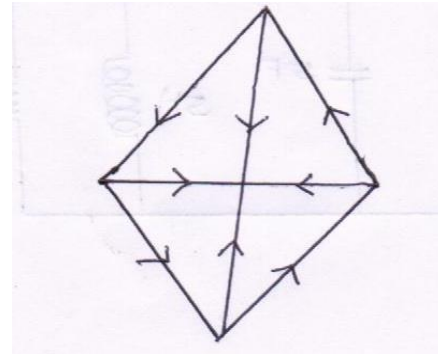
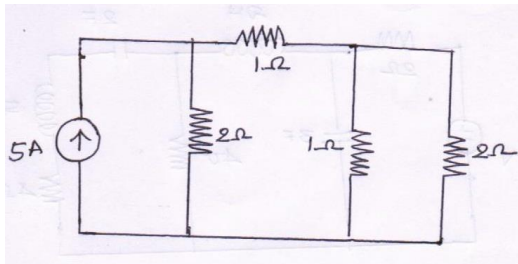

2. Find the tieset matrix for the followings?

a) [L3][CO3][5M]

b) [L3][CO3][5M]

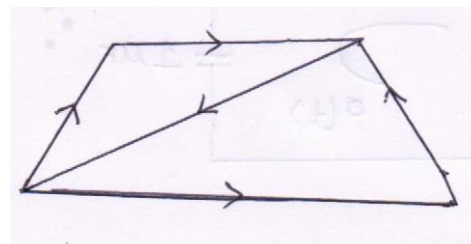
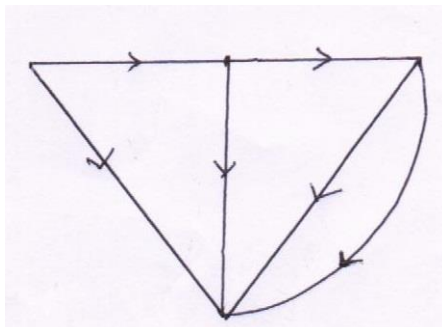

3. Determine current in 10Ω resistor for the following network by using nodal analysis.

[L4][CO3][10M]

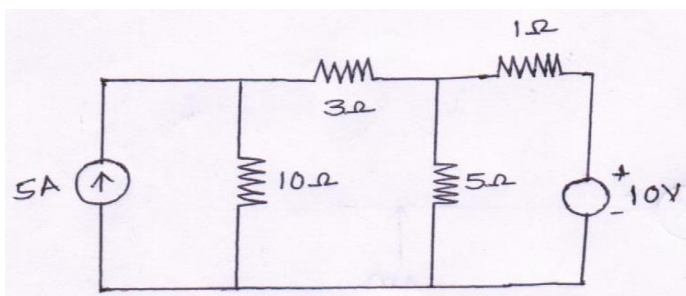

4. Find voltage V for the circuit shown in fig which makes the current in the 10Ω resistor is zero by using nodal analysis? [L4][CO3][10M]

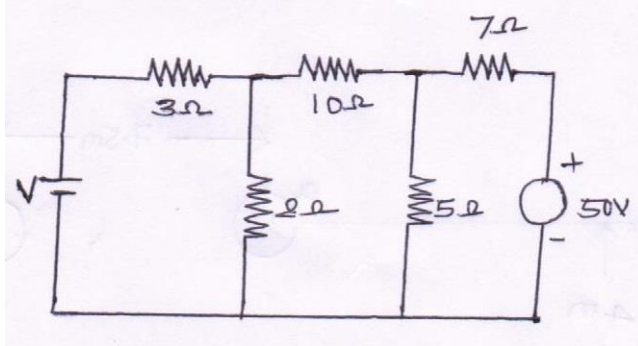

5. Determine current in 5Ω resistor for the circuit shown in figure. [L5][CO3][10M]

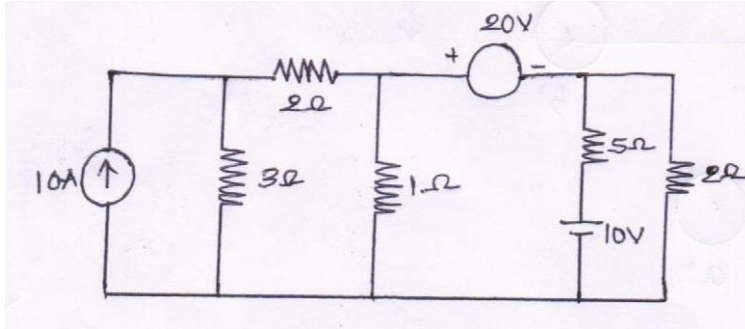

6. Determine mesh currents for the following network. [L5][CO3][10M]

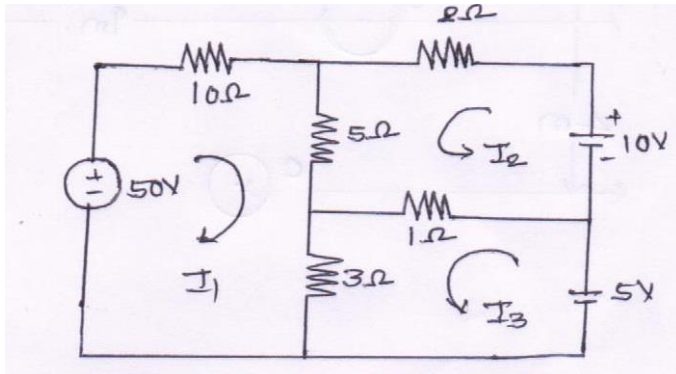

7. Determine i_x for the following network. [L5][CO3][10M]

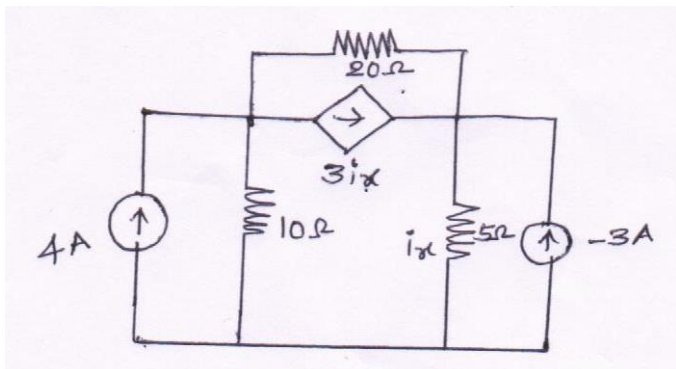

8. For the circuit shown in figure. Find the voltage across 4Ω resistor using nodal analysis. [L2][CO3][10M]

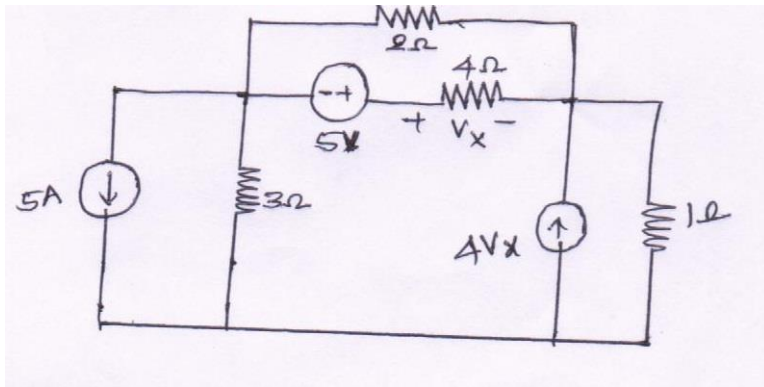

9. Write the procedure to draw the dual network and find dual network for the followings.

a)

[L4][CO3][5M]

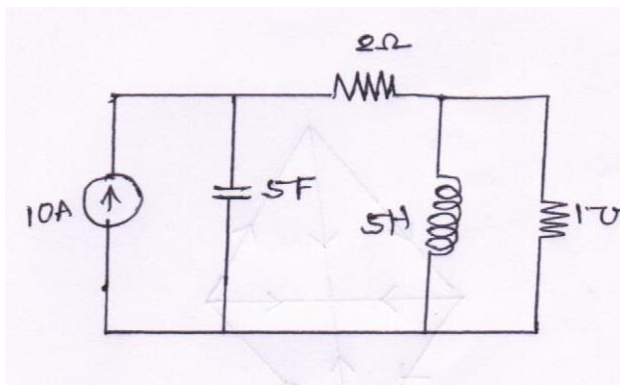

b)

[L3][CO3][5M]

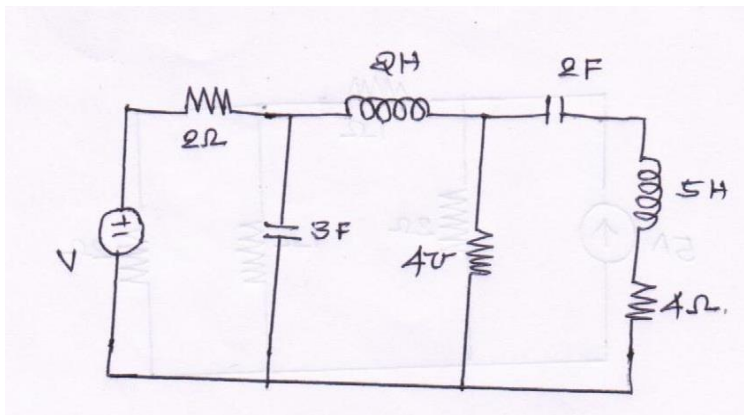

10. a) Define graph.

[L1][CO3][2M]

b) Define planar and non-planar graph.

[L1][CO3][2M]

c) Define duality.

[L1][CO3][2M]

d) Define cutset.

[L1][CO3][2M]

e) Define tieset.

[L1][CO3][2M]



SIDDHARTH GROUP OF INSTITUTIONS :: PUTTUR
Siddharth Nagar, Narayanavanam Road – 517583

QUESTION BANK (DESCRIPTIVE)

Subject with Code : EC-II (19EE0202)

Course & Branch: B.Tech - EEE

Year & Sem: II-B.Tech & I-Sem

Regulation: R19

UNIT-IV

TWO PORT NETWORKS

1. Derive the expressions for Z-parameters in terms of ABCD parameters. [L3][CO5][10M]
2. Find the Z - parameters for the resistance network shown in figure (B) [L2][CO5][10M]

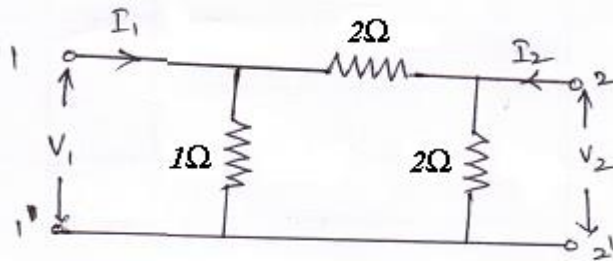

3. Find the Y - parameters for the resistance network shown in figure (b) [L2][CO5][10M]

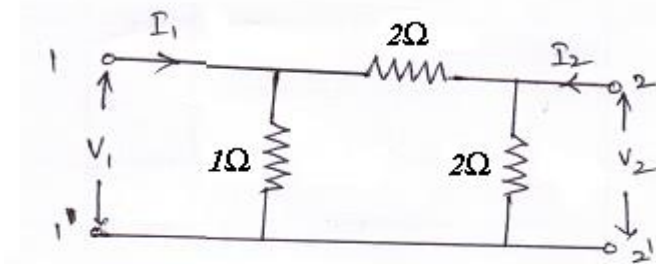

4. Derive the expressions for Y-parameters in terms of ABCD parameters? [L3][CO5][10M]
5. Derive the expressions for h-parameters of a two port network? [L3][CO5][10M]
6. Determine Y parameters of the following network [L4][CO5][10M]

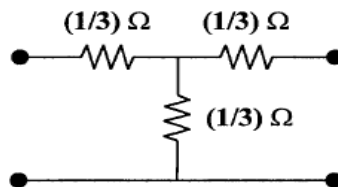

7. Obtain h and g parameters of following two port network. [L5][CO5][10M]

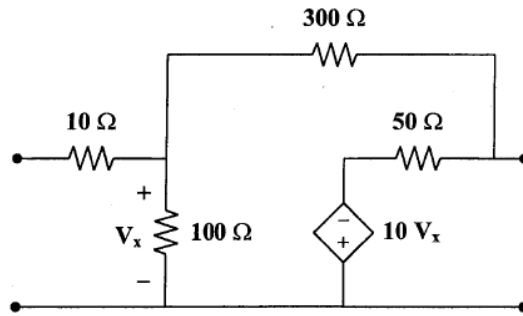

8. Obtain the T parameters of the following two port network

[L5][CO5][10M]

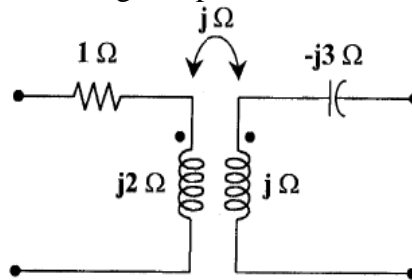

9. Prove the g parameters can be obtained from the z parameters as

[L6][CO5][10M]

$$g_{11} = \frac{1}{z_{11}} \quad g_{12} = \frac{-z_{12}}{z_{11}} \quad g_{21} = \frac{z_{21}}{z_{11}} \quad g_{22} = \frac{\Delta_z}{z_{11}}$$

10. Determine the Z parameters of the following two port network.

[L3][CO5][10M]

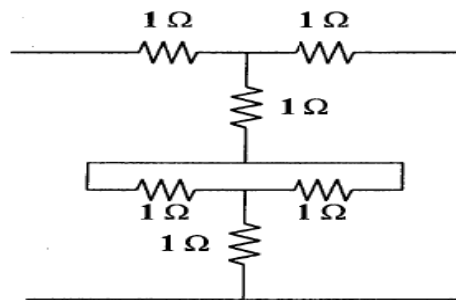



SIDDHARTH GROUP OF INSTITUTIONS :: PUTTUR
Siddharth Nagar, Narayanavanam Road – 517583

QUESTION BANK (DESCRIPTIVE)

Subject with Code : EC-II (19EE0202)

Course & Branch: B.Tech - EEE

Year & Sem: II-B.Tech & I-Sem

Regulation: R19

UNIT – V
ANALYSIS OF ELECTRICAL CIRCUITS USING LAPLACE
TRANSFORMS

- 1.a) Define Laplace transform of a function. [L1][CO6][5M]
b) Derive Laplace transform of all standard signals [L3][CO6][5M]
2. Find the signal $y(t)$, the Laplace transform of signal which is $Y(S) = \frac{S^3 + 7S^2 + 18S + 20}{S^2 + 5S + 6}$ [L4][CO6][10M]
3. Find the inverse Laplace transform of $F(S) = \frac{1}{(S+2)^2}$ [L4][CO6][10M]
4. Using the initial value theorem, find the initial value of the signal corresponding to the Laplace transform. $Y(S) = \frac{S+1}{S(S+2)}$ [L2][CO6][10M]
5. A 500Ω resistor, a 16mH inductor, and a 25 nF capacitor are connected in parallel which is placed in series with a 2000Ω resistor. Express the impedance of this series combination as a rational function of s . [L4][CO6][10M]
6. A $1\text{k}\Omega$ resistor is in series with a 500mH inductor. This series combination is in parallel with a $0.4\mu\text{F}$ capacitor. Express the equivalent s -domain impedance of these parallel branches as a rational functional. [L4][CO6][10M]
7. The energy stored in the circuit shown is zero at the time when the switch is closed. (A) find the s - domain expression for I (B) find the time domain expression for i when $t > 0$. (c) find the s - domain expression for V . (d) find the time domain expression for v when $t > 0$. [L3][CO6][10M]

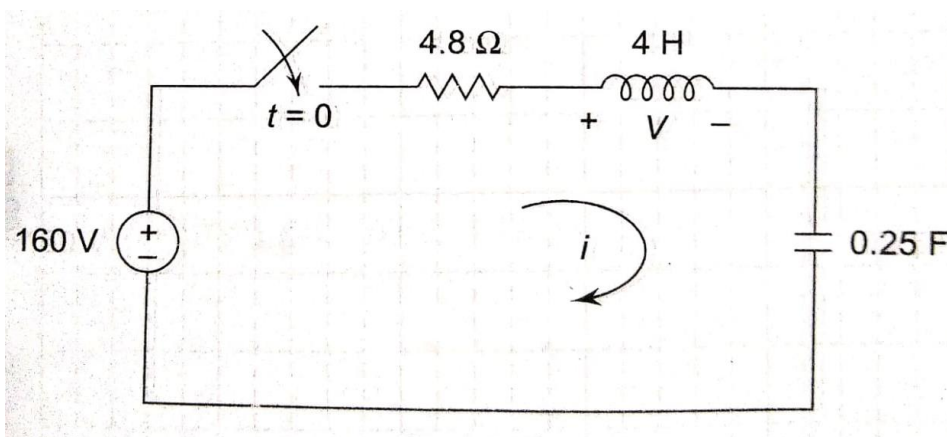

8. Derive the numerical expression for the transfer function v_o/I_g for the circuit shown.

[L3][CO6][10M]

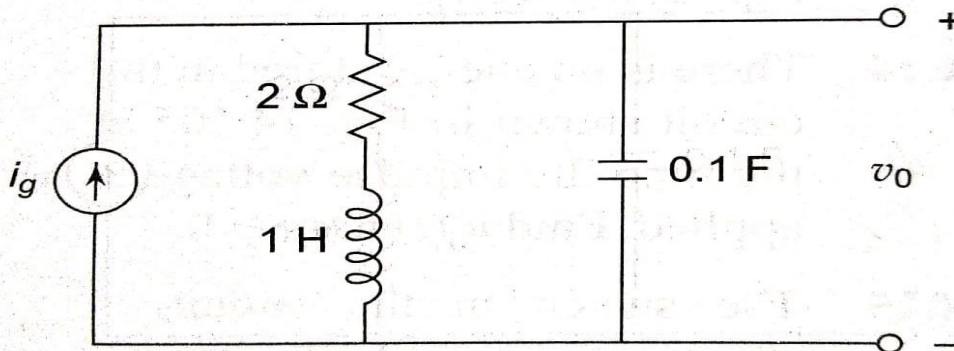

9. The unit impulse response of a circuit is

[L3][CO6][10M]

$$v_o(t) = 10,000e^{-70t} \cos(240t + \theta)u(t)\text{V} \text{ Where } \tan\theta = \frac{7}{24}$$

(A) Find the transfer function of the circuit. (B) Find the unit step response of the circuit.

10. There is no energy stored in the circuit shown in at the time the impulse voltage is applied.

Find $v_o(t)$ for $t \geq 0$.

[L3][CO6][10M]

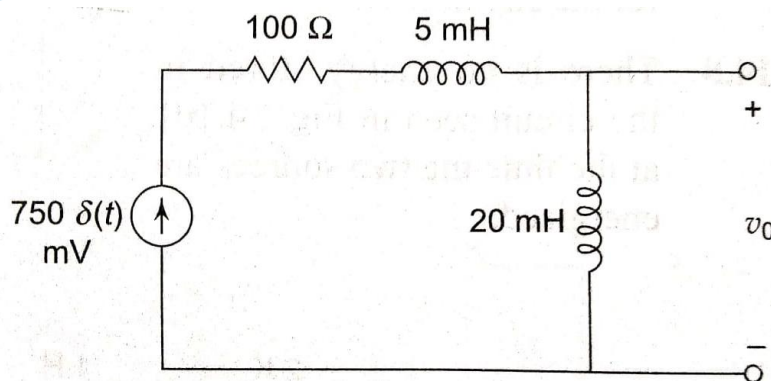

Prepared by

Dr. N. Ramesh Raju

Dr. Challa Babu